

# Freedom | HW

HINGED, 2 COVER SCREWS



## CONSTRUCTION

<b>Material</b>	Hot Compression Molded Fiberglass Reinforced Polyester (Thermoset)
<b>Gasket</b>	Poured Seamless Polyurethane Gasket
<b>Cover Screw Material</b>	304 Stainless Steel
<b>Cover Screw Size</b>	#10-32 x 1-1/4
<b>Cover Screw Torque</b>	20-24 in.-lbs.
<b>Hinge Hardware</b>	304 Stainless Steel

## INDUSTRY STANDARDS

<b>UL/cUL File #</b>	E64358
<b>NEMA Ratings (UL508A, UL50 &amp; UL50e)</b>	1, 3, 3S, 4X, 12, 13
<b>CSA Std. C22.2 File #</b>	LR069014
<b>IEC 60529 Ratings</b>	IP66
<b>UL 1741 File #</b>	E333478
<b>Temperature Range</b>	(-76°F to +274°F) (-60°C to +134°C)
<b>Flammability Rating</b>	UL94-5V
<b>Self Extinguishing</b>	Non-Halogenated, Non-flame propagating
<b>NFPA No. 101 Flame Spread</b>	Class A (1)
<b>Impact Rating</b>	IK10
<b>Certifications</b>	UL, CSA, CE, REACH, RoHS
<b>Outdoor UV Exposure (UL 746C)</b>	(f1) Rated
<b>Chemical Resistance</b>	See chart on page 120

## ACCESSORIES

### PANELS

<b>Aluminum Back Panel</b>	BP__A	pg. 108
<b>Carbon Steel Back Panel</b>	BP__CS	pg. 108

### ACCESSORIES

<b>Mounting Feet</b>	pg. 81
<b>Drain &amp; Breather Vents</b>	pg. 102
<b>PluggIt</b>	pg. 103
<b>Panel Management System</b>	pg. 76-81
<b>All Other Accessories</b>	Pg. 102-117

## MODIFICATIONS

<b>Custom Colors</b>	pg. 10-11
<b>Silk Screening</b>	pg. 10-11
<b>EMI/RFI Shielding</b>	pg. 10-11
<b>Custom Window</b>	pg. 10-11
<b>Custom Cutouts/Holes</b>	pg. 10-11



## CONSTRUCTION

<b>Material</b>	Hot Compression Molded Fiberglass Reinforced Polyester (Thermoset)
<b>Gasket</b>	Poured Seamless Polyurethane Gasket
<b>Cover Screw Size</b>	#10-32 x 1-1/4
<b>Cover Screw Torque</b>	20-24 in.-lbs.
<b>Hinge and Latch Hardware</b>	304 Stainless Steel

## INDUSTRY STANDARDS

<b>UL/cUL File #</b>	E64358
<b>NEMA Ratings (UL508A, UL50 &amp; UL50e)</b>	1, 3, 3S, 4X, 12, 13
<b>CSA Std. C22.2 File #</b>	LR069014
<b>IEC 60529 Ratings</b>	IP66
<b>UL 1741 File #</b>	E333478
<b>Temperature Range</b>	(-76°F to +274°F) (-60°C to +134°C)
<b>Flammability Rating</b>	UL94-5V
<b>Self Extinguishing</b>	Non-Halogenated, Non-flame propagating
<b>NFPA No. 101 Flame Spread</b>	Class A (1)
<b>Impact Rating</b>	IK10
<b>Certifications</b>	UL, CSA, CE, REACH, RoHS
<b>Outdoor UV Exposure (UL 746C)</b>	(f1) Rated
<b>Chemical Resistance</b>	See chart on page 120

## ACCESSORIES

### PANELS

<b>Aluminum Back Panel</b>	BP__A	pg. 108
<b>Carbon Steel Back Panel</b>	BP__CS	pg. 108

### ACCESSORIES

<b>Mounting Feet</b>	pg. 81
<b>Drain &amp; Breather Vents</b>	pg. 102
<b>Pluggit</b>	pg. 103
<b>Panel Management System</b>	pg. 76-81
<b>All Other Accessories</b>	Pg. 102-117

## MODIFICATIONS

<b>Custom Colors</b>	pg. 10-11
<b>Silk Screening</b>	pg. 10-11
<b>EMI/RFI Shielding</b>	pg. 10-11
<b>Custom Window</b>	pg. 10-11
<b>Custom Cutouts/Holes</b>	pg. 10-11

# Freedom | HW & HPL

TECHNICAL DRAWINGS / DIMENSIONS

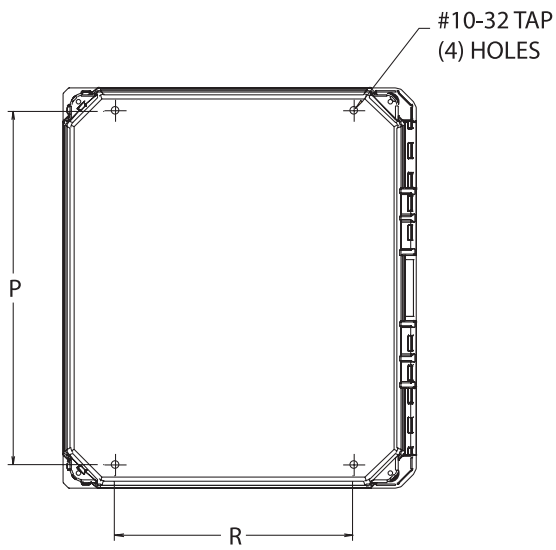

REAR VIEW

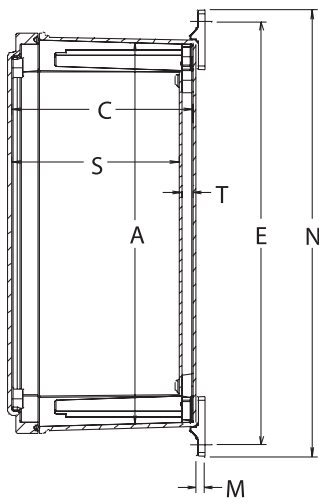
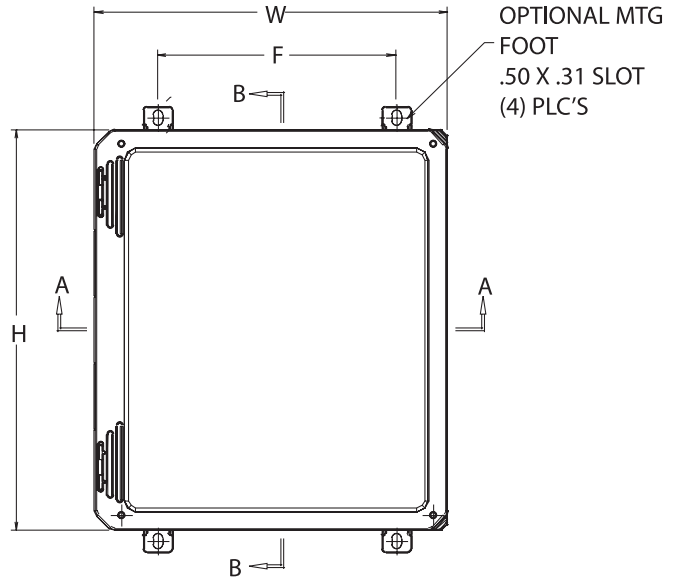

SECTION B-B

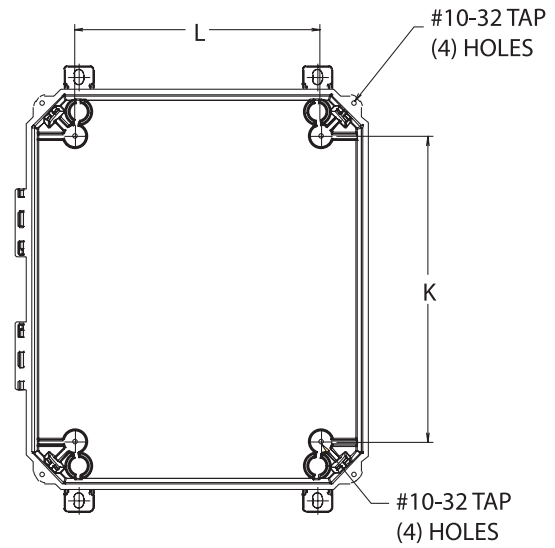

COVER  
REMOVED

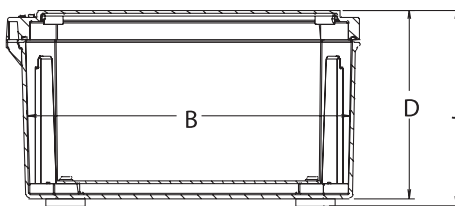

SECTION A-A

## FREEDOM OPAQUE COVER SERIES ENCLOSURES

SIZE ID NUMBER	OVERALL H X W X D	INSIDE A X B X C	MOUNTING P X R	K	L	S	T	OPT. MOUNT. FEET E X F	N	J	M	SHIPPING WEIGHT	PANEL NUMBER
<b>FR60604HW</b> <b>FR60604HPL</b>	7.41 x 7.79 x 4.31 (188 x 198 x 110)	6.77 x 6.77 x 4.06 (172 x 172 x 103)	5.93 x 4.00 (151 x 102)	4.25 (108)	4.25 (108)	3.60 (92)	.38 (10)	8.24 x 4.00 (209 x 102)	9.02 (229)	4.56 (116)	.25 (6)	3.8 lbs	BP66*
<b>FR80604HW</b> <b>FR80604HPL</b>	9.41 x 7.79 x 4.31 (239 x 198 x 110)	8.77 x 6.77 x 4.06 (223 x 172 x 103)	7.91 x 4.00 (201 x 102)	6.25 (159)	4.25 (108)	3.60 (92)	.38 (10)	10.21 x 4.00 (259 x 102)	10.98 (279)	4.56 (116)	.25 (6)	4.1 lbs	BP86*
<b>FR80804HW</b> <b>FR80804HPL</b>	9.39 x 9.76 x 4.31 (239 x 248 x 109)	8.74 x 8.74 x 4.06 (222 x 222 x 103)	7.91 x 6.00 (201 x 152)	6.25 (159)	6.25 (159)	3.60 (92)	.38 (10)	10.21 x 6.00 (259 x 152)	10.98 (279)	4.56 (116)	.25 (6)	4.9 lbs	BP88*
<b>FR100806HW</b> <b>FR100806HPL</b>	11.42 x 9.79 x 6.31 (290 x 249 x 160)	10.73 x 8.73 x 6.06 (273 x 222 x 154)	9.89 x 6.00 (251 x 152)	8.25 (210)	6.25 (159)	5.60 (142)	.38 (10)	12.19 x 6.00 (310 x 152)	12.96 (329)	6.56 (167)	.25 (6)	6.2 lbs	BP108*
<b>FR121006HW</b> <b>FR121006HPL</b>	13.45 x 11.83 x 6.31 (342 x 301 x 160)	12.69 x 10.69 x 6.06 (322 x 272 x 154)	11.88 x 8.00 (302 x 203)	10.25 (260)	8.25 (210)	5.60 (142)	.38 (10)	14.18 x 8.00 (360 x 203)	14.95 (380)	6.56 (167)	.25 (6)	8.0 lbs	BP1210*
<b>FR141206HW</b> <b>FR141206HPL</b>	15.44 x 13.86 x 6.34 (392 x 352 x 161)	14.72 x 12.72 x 6.06 (374 x 323 x 154)	13.91 x 10.00 (353 x 254)	12.25 (311)	10.25 (260)	5.60 (142)	.38 (10)	16.21 x 10.00 (412 x 254)	16.98 (431)	6.59 (167)	.25 (6)	10.0 lbs	BP1412*
<b>FR141208HW</b> <b>FR141208HPL</b>	15.44 x 13.86 x 8.34 (392 x 352 x 212)	14.66 x 12.66 x 8.06 (372 x 322 x 205)	13.91 x 10.00 (353 x 254)	12.25 (311)	10.25 (260)	7.60 (193)	.38 (10)	16.19 x 10.00 (411 x 254)	16.96 (431)	8.59 (218)	.25 (6)	12.5 lbs	BP1412*
<b>FR161408HW</b> <b>FR161408HPL</b>	17.58 x 15.96 x 8.34 (447 x 405 x 212)	16.69 x 14.69 x 8.06 (424 x 373 x 205)	15.96 x 12.00 (405 x 305)	14.25 (362)	12.25 (311)	7.60 (193)	.38 (10)	18.26 x 12.00 (464 x 305)	19.04 (484)	8.59 (218)	.25 (6)	13.3 lbs	BP1614*
<b>FR181610HW</b> <b>FR181610HPL</b>	19.77 x 18.15 x 10.34 (502 x 461 x 263)	18.63 x 16.63 x 10.06 (473 x 422 x 256)	17.94 x 14.00 (456 x 356)	16.25 (413)	14.25 (362)	9.60 (244)	.38 (10)	20.24 x 14.00 (514 x 356)	21.02 (534)	10.59 (269)	.25 (6)	20.2 lbs	BP1816*
<b>FR201610HW</b> <b>FR201610HPL</b>	21.79 x 18.16 x 10.34 (554 x 461 x 263)	20.63 x 16.63 x 10.06 (524 x 422 x 256)	19.96 x 14.00 (507 x 356)	18.25 (463)	14.25 (362)	9.59 (244)	.38 (10)	22.26 x 14.00 (566 x 356)	23.04 (585)	10.59 (269)	.25 (6)	21.7 lbs	BP2016*

All measures are in inches, items in parentheses are in millimeters.

\*Panel sold separately.

\*\* Clear cover option available. Consult factory.

\*\*\* Screw down cover option available. Consult factory.

\*\*\*\* HLL cover option available. Consult factory.